



Contents lists available at ScienceDirect

Nuclear Instruments and Methods in Physics Research A

journal homepage: www.elsevier.com/locate/nima

Status of CHESSE facility and research programs: 2010

Ernest Fontes*, Donald H. Bilderback, Sol M. Gruner

Cornell High Energy Synchrotron Source, Cornell University, Ithaca, NY 14853, USA

ARTICLE INFO

Available online 9 December 2010

Keywords:

National X-ray User Facility
CHESSE
NSF

ABSTRACT

CHESSE is a hard X-ray synchrotron radiation national facility located at Cornell University and funded by the National Science Foundation. It is open to all scientists by peer-reviewed proposal and serves 500–1000 visitors each year. The CHESSE scientific and technical staff develops forefront research tools and X-ray instrumentation and methods and supports 12 experimental stations delivering high intensity X-ray beams produced at 5.3 GeV and 250 mA. The facility consists of a mix of dedicated and flexible experimental stations that are easily configured for general X-ray diffraction (wide- and small-angle), spectroscopy, imaging applications, etc. Dedicated stations support high-pressure powder X-ray diffraction, pulsed-laser deposition for layer-by-layer growth of surfaces, and three dedicated stations for protein crystallography. Specialized resource groups at the laboratory include: an X-ray detector group; MacCHESSE, an NIH-supported research resource for protein crystallography; the G-line division, which primarily organizes graduate students and Cornell faculty members around three X-ray stations; a high-pressure diamond-anvil cell support laboratory; and a monocapillary drawing facility for making microbeam X-ray optics. Research is also ongoing to upgrade CHESSE to a first-ever 5 GeV, 100 mA Energy Recovery Linac (ERL) hard X-ray source. This source will provide ultra-high spectral-brightness and < 100 fs short-pulse capability at levels well in advance of those possible with existing storage rings. It will produce diffraction-limited X-rays beams of up to 10 keV energy and be capable of providing 1 nm round beams. Prototyping for this facility is under way now to demonstrate critical DC photoelectron injector and superconducting linac technologies needed for the full-scale ERL.

© 2010 Elsevier B.V. All rights reserved.

CHESSE encompasses a multifaceted research program that supports X-ray research, instrument, beamline, and storage ring development, as well as an accelerator R&D program aimed at upgrading the existing facility to realize the first high-energy Energy Recovery Linac (ERL) source. The Cornell Electron Storage Ring (CESR) source for CHESSE was used for more than three decades for both high energy physics and synchrotron light production. CHESSE was a parasitic X-ray source for 25 years and has successfully made the transition to a dedicated X-ray source since 2003. Continuing from the past, CHESSE utilizes radiation from both electrons and positrons simultaneously, feeding 12 experimental stations (five bend magnet and seven wiggler fed) that serve 500–1000 visiting scientists and students each year. To improve two-beam running conditions, efforts are directed to increase the number of bunches in each beam by reducing the spacing between bunches. With the help of a new high bandwidth digital feedback system it is now possible to space bunches as few as 4 ns apart (rather than the usual 14 ns). Increasing the number of bunches reduces the charge per bunch, enabling smaller source sizes and longer lifetimes of electron and positron beams.

Another machine project important for CHESSE near-term planning is developing single-beam low-emittance optics in order to further reduce beam size and to prepare for undulator sources to feed CHESSE beamlines. This builds on the CesrTA program, which is a test accelerator project to study low-emittance damping rings for the International Linear Collider. At the end of the most recent CHESSE run, a week of electrons-only and positrons-only running was scheduled. CESR ran with a low-emittance lattice suitable for undulators, and we observed the expected 40% smaller focused spot sizes in some of our focused beamlines.

The X-ray instruments and user programs at the facility are undergoing constant replenishment. One program that impacts many research efforts is the capillary fabrication efforts of Don Bilderback and his group, which provides micron-sized beams for a large number of beamlines and applications at CHESSE. These include capillaries for high-energy focusing used for high-pressure diamond-anvil cell (DAC) research, macromolecular wide-band-pass Laue diffraction, and scanning X-ray fluorescence microscopy.

The high-pressure science program, headed by Zhongwu Wang, is moving strongly in the direction of nanoparticle supercrystals, mesostructures, and bio-inspired nano-related materials. The B2 station instrument suite will soon include radial-diffraction DACs, laser and resistive heating, and high-energy focusing (with capillaries and Laue optics). X-ray fluorescence imaging is growing in usefulness

* Corresponding author.

E-mail address: ef11@cornell.edu (E. Fontes).

as a tool for studying chemical and spatial distributions in a non-destructive manner for art history and conservation, archeology, dendrochronology, classics, and environmental sciences. Instrumentation improvements include procuring faster detectors, extending the spectrum to higher-energy, and deploying user friendly software with rapid analysis capabilities.

Led by staff scientist Ken Finkelstein, the C-line station is being upgraded to support resonant X-ray scattering (RXS) and absorption/emission spectroscopy at low and high energies (2–30 keV) with emphasis on biophysics, novel magnetic and electronic phases, and chemical catalysis. Ongoing upgrades to the beamline include removing all beryllium vacuum windows, adding a new white-beam vertical focusing mirror, and building a new back-scattering analyzer (see Fig. 1).

Detlef Smilgies, staff scientist for the D1 station, is working to improve support for small-angle, wide-angle, and grazing incidence scattering to probe the structure of thin films and nanostructures with applications in organic electronics, block copolymers, self-assembly, biological thin films, and liquid crystals. New capabilities include the ability to scan an X-ray microbeam across heterogeneous specimens, a new optical inspection bench, and new automatic alignment options for the optical microscope. We are also developing plans for faster area detectors (100 Hz or better) that will make rapid annealing and *in-situ* processing measurements possible.

There are always many ongoing X-ray optics projects under the direction of staff scientist Alex Kazimirov. New research support specialist David Agyeman-Budu is working with scientist Arthur Woll to design and fabricate, at the Cornell Nanofabrication Facility, micro-sized linear-tapered collimators for use in confocal X-ray fluorescence microscopy. A Talbot interferometer has been built by graduate student Robin Baur and scientist Darren Dale. Preliminary data taken at the F3 experimental station show intriguing images of insects trapped in Baltic amber. A new portable X-ray fluorescence analysis station was designed and built by scientist Peter Revesz and engineers Alan Pauling and Eric Edwards (see Fig. 2). Using a compact X-ray source and detector by Amptek, Inc., the station was designed for outreach and educational hands-on activities with school groups and teacher training without needing to use synchrotron beamlines or stations.

The macromolecular research program supported by the National Institutes of Health is called MacCHESS. MacCHESS presently supports five major research initiatives. Staff scientist Ulrich Englich has taken over the microcrystallography initiative. Microfocused X-ray beams are now routinely available, on request, at all MacCHESS beamlines,



Fig. 2. REU student Katherine Spoth (right) leads an outreach activity using the new portable X-ray fluorescence station (in red) with staff scientist Peter Revesz. (For interpretation of the references to color in this figure legend, the reader is referred to the web version of this article).

and potential users are shown many examples of how microbeams can significantly improve diffraction statistics. The high-pressure cryocrystallography initiative, headed by scientist Chae Un Kim, offers users' access to sample preparation conditions that are available nowhere else in the world at present time. High-pressure cryocooling can not only reduce or eliminate the need for cryoprotection, but also improve ligand occupancy, reveal conformational movements, and improve phasing with Kr and Xe. MacCHESS's new high-pressure facility, located next to the chemistry room, can reach up to 2000 atm. Interested users should contact Chae Un Kim or research support specialist Irina Kriksunov. Long-wavelength crystallography is possible now at the F3 station. Reaching down to 6.5 keV, users can phase proteins using SAD with elements such as Fe and Cr.

New to MacCHESS is a BioSAXS (biological small-angle X-ray solution scattering) initiative led by scientist Richard Gillilan. Rising demand for BioSAXS time worldwide and falling interest in full MAD phasing has prompted MacCHESS to reconfigure the F2 line as an automated BioSAXS station. A robotic sample-loading SAXS system is now available, which can handle up to 96 samples at a time. New software has also been designed both for robot control and for data processing. Finally, a BAM-2 automounter for crystallography is being constructed for A1 station. This initiative, headed by scientist Dave Schuller and engineer Mike Cook, is based on the latest design from Lawrence Berkeley Lab. The BAM-2 uses a 3-axis system that will be more flexible and easier to configure than previous designs. It is expected to come online for testing by Spring 2011.

The ERL prototyping program is making steady progress towards designing and testing key technologies needed to realize a transversely coherent hard X-rays source (5 GeV, 100 mA) as a user facility. Several advantages of ERLs over storage ring light sources are exceedingly large average spectral brightness of 10^{23} in usual units and a natural pulse length of 2 ps that can be compressed to < 100 fs with a repetition rate of 1.3 GHz, as well as a source size of several microns, which should allow state-of-the-art optics to focus X-ray beams down to the nanometer scale. With support from New York State, an architectural study has been completed that shows how such a hard X-ray ERL facility could be located on Cornell's campus. NSF has funded both the Phase 1A and 1B portions of the R&D project; 1B funding will continue the project for four more years. The results with Phase 1A funds include successful development of a photocathode gun, superconducting ERL injector linac (5–15 MeV), and diagnostic beamline. Recent photo-injector milestones are the highest achieved current—25 mA DC, 9 mA bunched, the highest DC gun voltage—430 kV, and the highest achieved bunch charge—80 pC (the design value). The low-emittance diagnostics data compared well with beam simulations. The role of ten graduate students in accelerator physics at Cornell is a particularly important project feature,

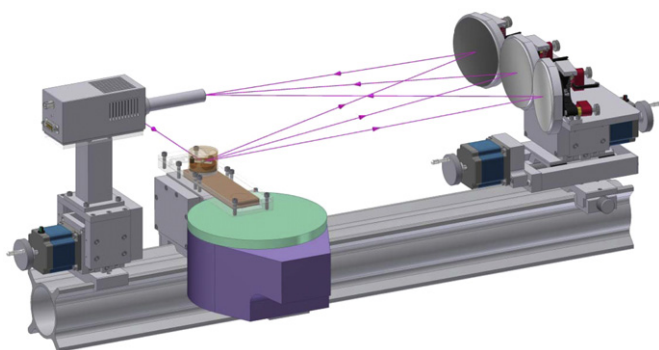

Fig. 1. First CHESS X-ray emission spectrometer, designed by staff scientist Ken Finkelstein and engineer Aaron Lyndaker, is illustrated. Five independently steerable and 100 mm diameter backscattering crystals on an adjustable Rowland circle achieve resolution better than 1 eV over an energy range suitable for Mn, Fe, and Co K β . The incident beam is doubly focused using a white-beam mirror and Si(1 1 1) mono to deliver 5×10^{11} photons/s at the sample. We have also added a displexer for low temperature studies and will soon install the crystals and flight path within a specially designed helium enclosure and offer the option of a high flux multi-layer mono.

with three of them in the superconducting radiofrequency science and technology program. Looking forward, six two-day science workshops are in the planning stage for 2011 to explore the scientific potential of a continuous-duty or CW source of greater than 1 MHz, repetition rate, coherent (fully diffraction-limited), or hard ($\lambda \leq 1.5 \text{ \AA}$) synchrotron X-ray source.

In conclusion, the CHES program is healthy and growing. The facility is moving toward single-beam operation with undulators in CESR in the near term and is continuing to rapidly develop the ERL concept by commissioning the prototype injector and shortly submitting a design study to the NSF for a future upgrade of CESR to an ERL.